



JOIN BANK OF AMERICA

NEARBY RETAILERS



RETAIL FOR LEASE

- 1,580 SF former salon and barbershop immediately available for lease.
- Unobstructed visibility from Martin Luther King Jr Ave SE (16,550 ADT) with parking in the rear.
- Ground level retail of ~100,000 SF office building. Primarily leased to the government of the District of Columbia.

DEVELOPED BY:



THE PEBBLES CORPORATION

VICTOR SALCIDO

victor@klnb.com | 240-755-2704

Martin Luther King Jr Ave SE

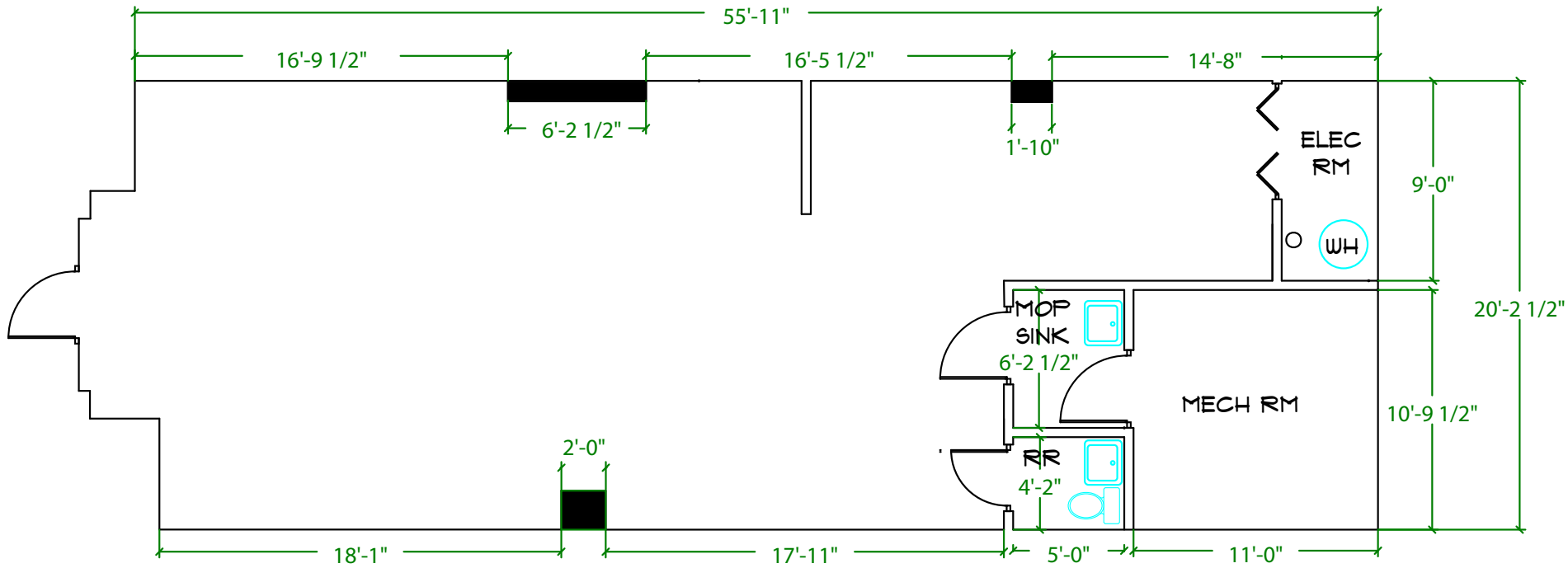

MID-VIEW

2100 MARTIN LUTHER KING JR AVE SE

WASHINGTON, DC 20020

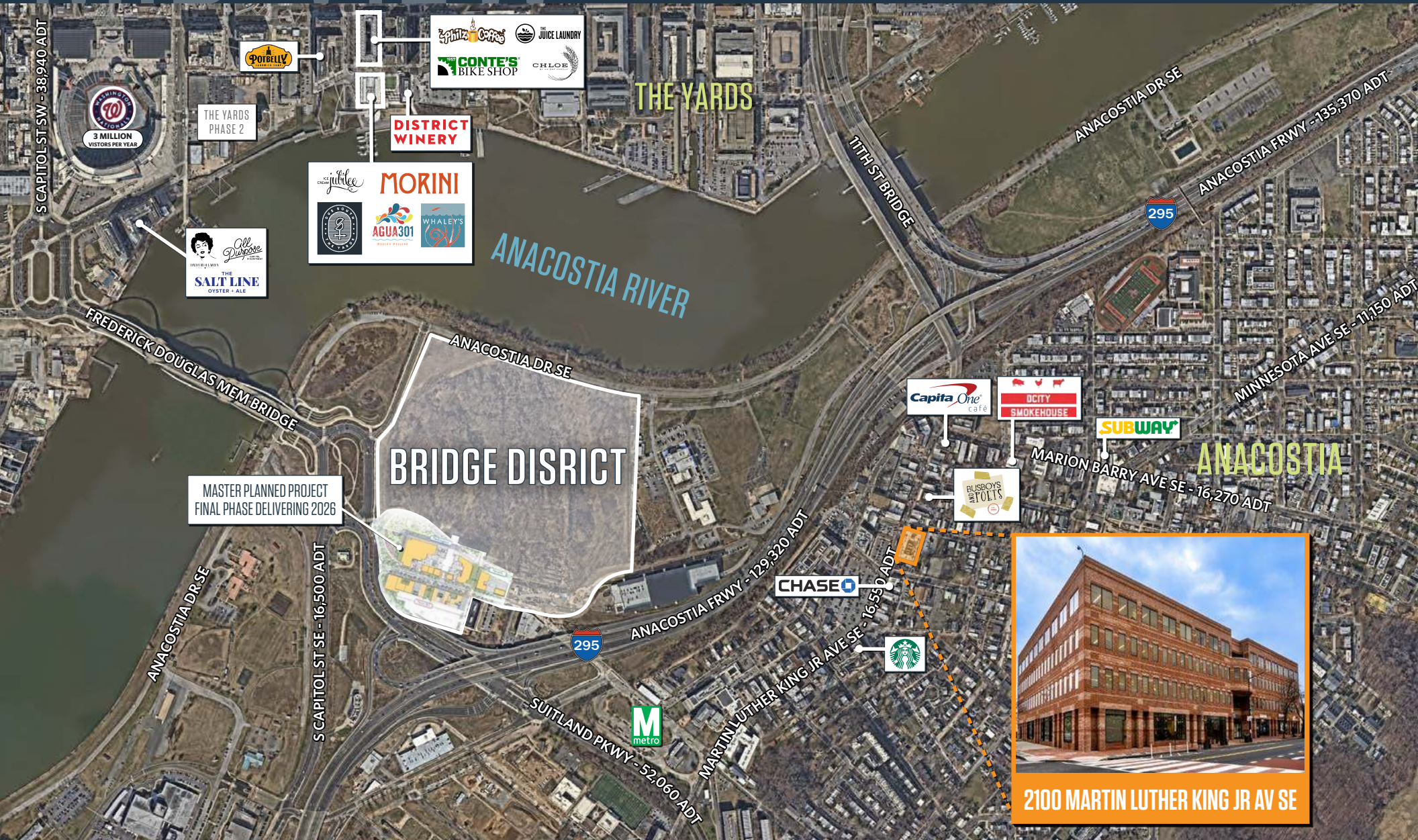

VICTOR SALCIDO

victor@klnb.com | 240-755-2704



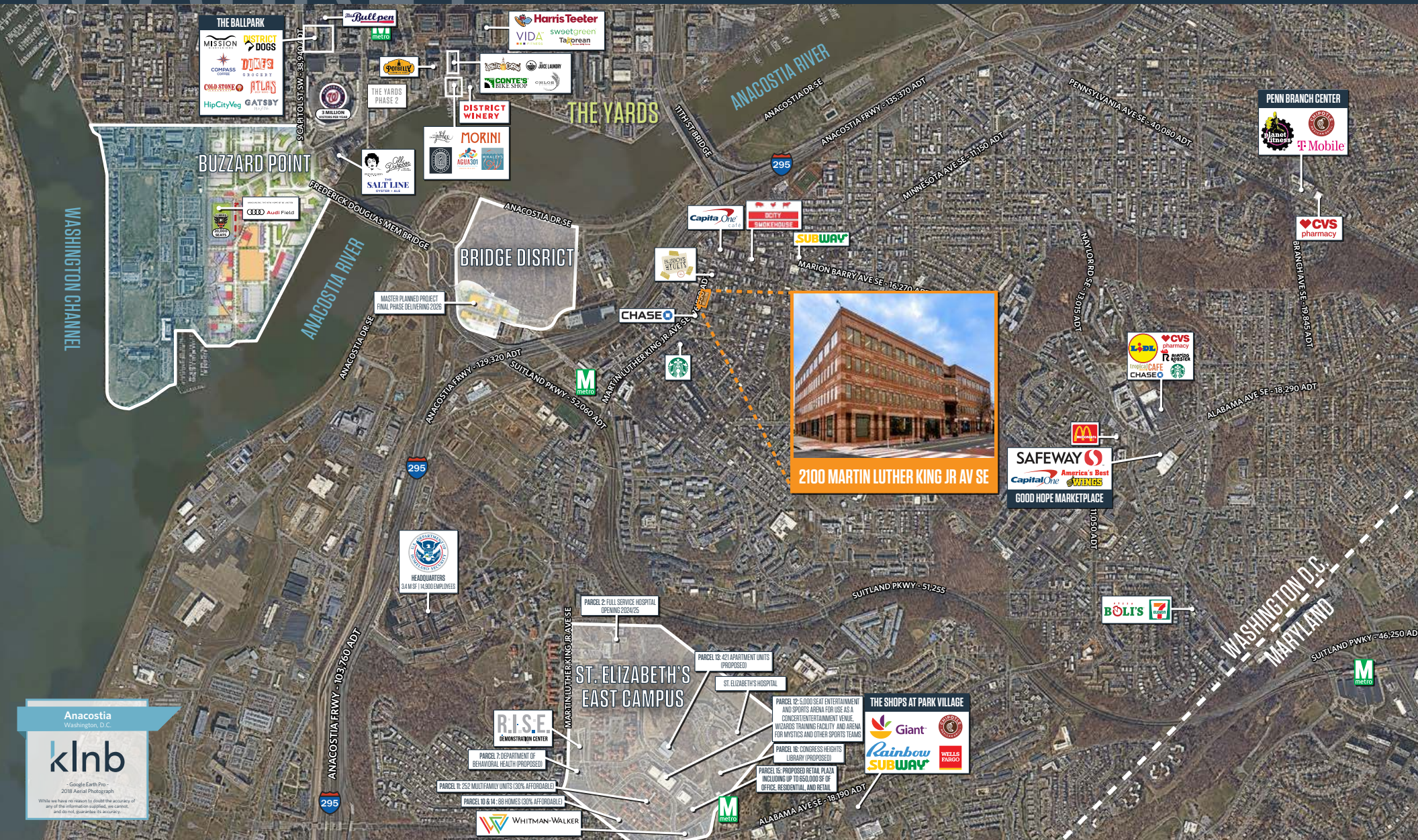

Anacostia
Washington, D.C.

Google Earth Pro -
2018 Aerial Photograph
While we have no reason to doubt the accuracy of
any of the information supplied, we cannot
and do not guarantee its accuracy.

LOCATION

2100 MARTIN LUTHER KING JR AVE SE

WASHINGTON, DC 20020

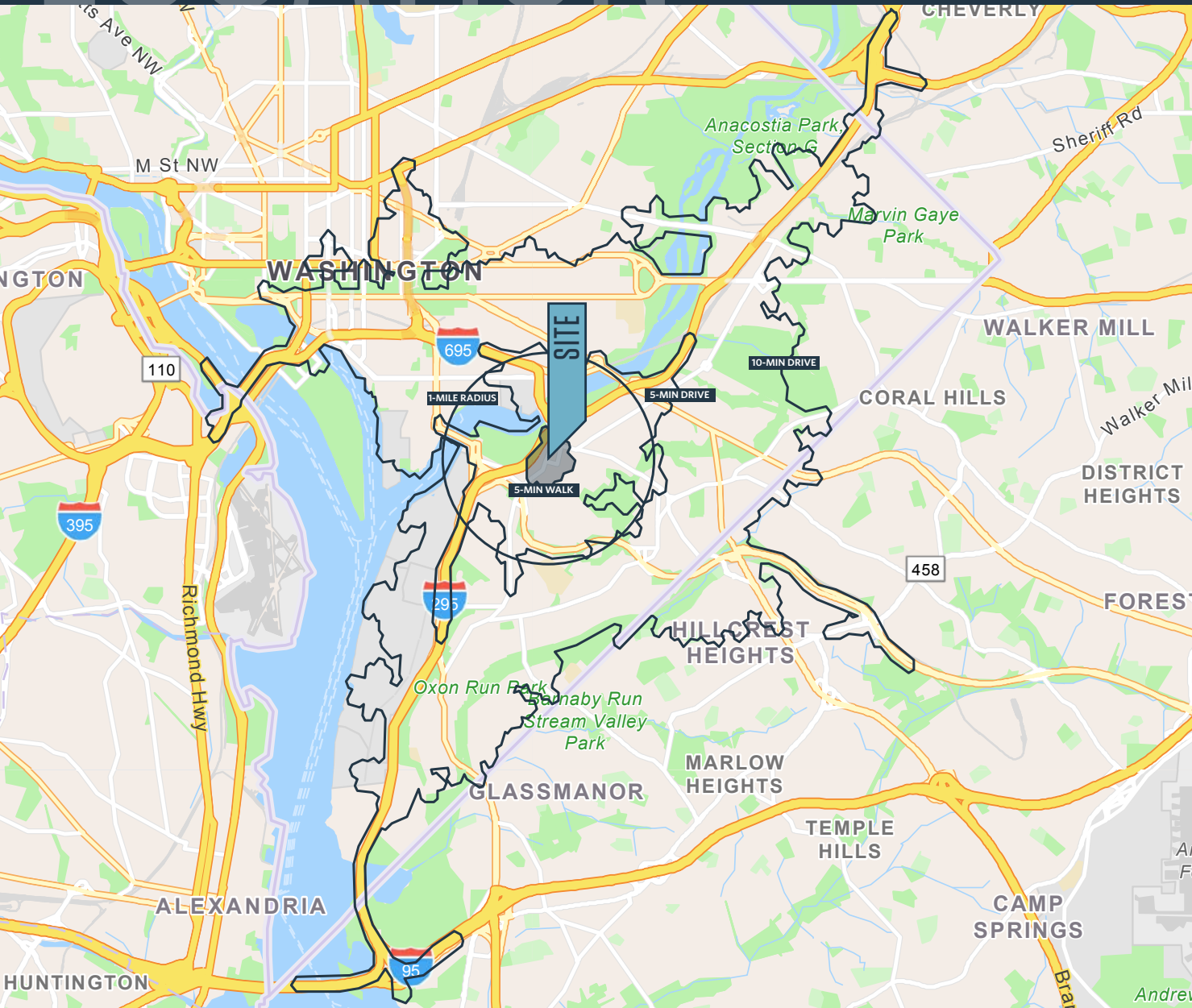

DEMOGRAPHICS | 2023:

	WALK TIME: 5-MIN	DRIVE TIME: 5-MIN	10-MIN	RADIUS: 1-MILE
Population	1,105	25,267	186,362	27,319
Daytime Population	1,965	10,121	202,860	11,230
Households	459	10,841	87,031	12,227
Average HH Income	\$94,230	\$78,165	\$122,335	\$86,306

[CLICK TO DOWNLOAD DEMOGRAPHIC REPORT](#)

TRAFFIC COUNTS | 2022:

Martin Luther King Jr Ave SE	16,550 ADT
Marion Barry Ave SE	16,270 ADT
Suitland Pkwy	52,060 ADT
Anacostia Frwy (I-295)	129,320 ADT

VICTOR SALCIDO

victor@klnb.com | 240-755-2704





2100 MARTIN LUTHER KING JR AVE SE

WASHINGTON, DC 20020

FOR MORE INFORMATION, PLEASE CONTACT:

VICTOR SALCIDO

victor@klnb.com

240-755-2740

8065 Leesburg Pike, Suite 700, Tysons, VA 22182

.....

klnb.com



[instagram.com/klnbcre](https://www.instagram.com/klnbcre)



[linkedin.com/company/klnb](https://www.linkedin.com/company/klnb)



[facebook.com/KLNBCRE](https://www.facebook.com/KLNBCRE)

CLICK TO VIEW PROPERTY WEBSITE

While we have no reason to doubt the accuracy of any of the information supplied, we cannot, and do not, guarantee its accuracy. All information should be independently verified prior to a purchase or lease of the property. We are not responsible for errors, omissions, misuse, or misinterpretation of information contained herein and make no warranty of any kind, express or implied, with respect to the property or any other matters.